



WARN Industrial Winch

Model	Part Number	Motor Type
Series 9-A-30 Hydraulic Winch Manual Clutch	30279	Hydraulic 3.0 ci (50 cc)

The Series 9 hydraulic winch features a 2-stage planetary gear train with a total reduction of 27:1. This winch uses a heavy duty automatic disc brake and a locking clutch lever. The 4" (102mm) steel drum provides excellent durability for the wire rope. Designed to meet SAE J706 and CE standards.

Due to the hydraulic motor sizing, this winch is designed for increased linespeed with a Rated Pulling Force of 7500 lbf (3402 kgf).



Accessories

Description:	Part Number
Wire Rope Tension Plate 10"	31149
Fairlead Black 10"	24336
Fairlead Chrome 10"	30859
Remote Clutch Mechanical	38316
Remote Clutch Air	71370
Wire Rope Assembly 3/8"x125' EIPS	23674

Engineering Data

Rated Pulling Force:	7500	lbf	3402	kgf
Drum Barrel Diameter:	4.00	in	102	mm
Drum Flange Diameter:	8.24	in	209	mm
Distance Between Flanges:	9.95	in	253	mm
Recommended Maximum Wire Rope Diameter:	1/2	in	12.7	mm
Recommended Minimum Wire Rope Breaking Strength:	15,100	lbf	6849	kgf
Approximate Shipping Weight:	80.0	lb	36.3	kg
Duty Cycle (intermittent per SAE J706 section 6.2):	305	ft	93	m
Mounting Bolt Torque:	35 - 40	ft*lbf	47 - 54	N*m
Maximum Layers of Wire Rope:	4 (with 3/8" dia. rope)			
Gear Reduction:	27:1			
Brake Type:	Disk			
Contactor / Remote Type:	N/A			

Drum Rotation



Viewed from Motor End

Standards Compliance

1. -SAE J706
2. -CE Machinery Directive 98/37/EC and 2006/42/EC

Performance By Layer- 3/8" (9.5 mm) dia. rope

Drum Layer	Line Load *			Line Speed 10 GPM		Line Speed 15 GPM		Drum Capacity	
	lbf	kgf	kN	ft/min	m/min	ft/min	m/min	ft	m
1	7500	3402	33.4	35.0	10.7	47.0	14.3	25	7.6
2	6400	2903	28.5	41.1	12.5	55.0	16.8	54	16.5
3	5585	2533	24.8	47.1	14.4	63.1	19.2	88	26.8
4	4953	2247	22.0	53.1	16.2	71.1	21.7	126	38.4

* Never exceed the Rated Pulling Force. Installation of a Rated Capacity Limiter is recommended.

First Layer Performance

Line Load		Pressure Drop at 10 GPM		Pressure Drop at 15 GPM		Duty Cycle
lbf	kgf	psi	BAR	psi	BAR	min/10min
0	0	250	17.2	400	27.6	N/A
1500	680	640	44.1	810	55.8	N/A
3000	1361	1070	73.8	1290	88.9	N/A
4500	2041	1530	105.5	1750	120.7	N/A
6000	2722	2000	137.9	2200	151.7	N/A
7500	3402	2600	179.3	(1)	(1)	N/A
9000	4082	(1)	(1)	(1)	(1)	N/A

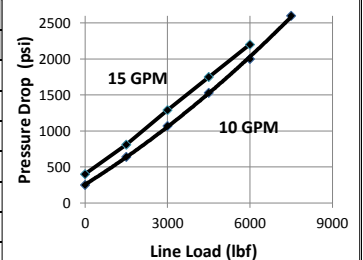
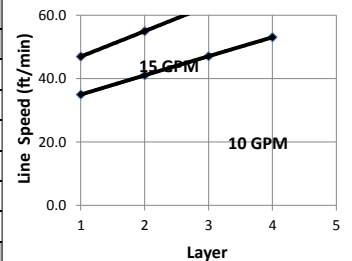

WARN INDUSTRIES, INC
Industrial Products

Customer Service (North America): 1.800.543.9276
Customer Service (International): 1.503.722.3008
FAX: 1.503.722.3000 www.warn.com

12900 S.E. Capps Road,
Clackamas, OR USA 97015



WARN Industrial Winch

Model	Part Number	Motor Type
Series 9-A-30 Hydraulic Winch Manual Clutch	30279	Hydraulic 3.0 ci (50 cc)

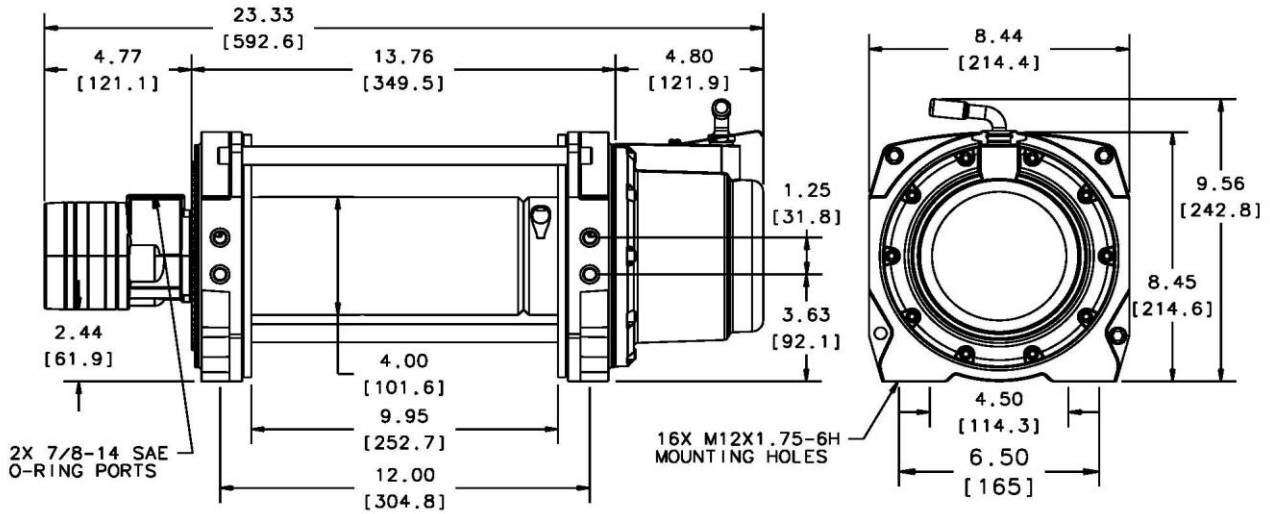

Motor / Contactor may be rotated in 180 degree increments. Clutch housing may be rotated in 72 degree increments.

Units are given in inches [millimeters], unless otherwise specified

Recommended Mounting- Always Observe Correct Drum Rotation			Hydraulic System Specifications		
Pull from bottom of winch	Pull from bottom of winch	Pull from top of winch	Maximum System Pressure:	2600 psi	179 BAR
			Maximum Motor Pressure Drop:	2600 psi	179 BAR
Feet down	Feet forward	Feet forward	Maximum Rated Input Flow:	15 GPM	57 LPM
Pull from top of winch	Pull from top of winch	Pull from top of winch	Control Valve Type:	3-position, 4-way, closed center, spring return (cylinder spool)	
			Control Valve Schematic		
Feet down without angle brace	Feet down with angle brace	Angle Braces Only			
			Notes: (1) Do Not Exceed 2600 psi motor pressure drop. (2) Drum rotates clockwise with Port A pressurized when viewed from gearbox end.		

WARN INDUSTRIES, INC
Industrial Products

Customer Service (North America): 1.800.543.9276
Customer Service (International): 1.503.722.3008
FAX: 1.503.722.3000 www.warn.com

12900 S.E. Capps Road,
Clackamas, OR USA 97015