



WARN Industrial Winch

Model

Part Number

Motor Type

Series 18-A-73 Hydraulic Winch Manual Clutch

74125

Hydraulic
7.3 ci
(120 cc)

The Series 18 hydraulic winch features a 2 stage planetary gear train with a total reduction of 36:1. This winch uses a heavy duty automatic disc brake and a locking clutch lever. The 4" (102mm) steel drum provides excellent durability for the wire rope. Designed to meet SAE J706 and CE standards.



Accessories

Description:
Wire Rope Tension Plate 10"
Fairlead Black 10"
Fairlead Chrome 10"
Remote Clutch Air
Remote Clutch Mechanical
Wire Rope Assembly 1/2"x75"

Part Number
31149
24336
30859
71370
38316
77534

Engineering Data

Rated Pulling Force:	18000	lbf	8165	kgf
Drum Barrel Diameter:	4.00	in	102	mm
Drum Flange Diameter:	8.24	in	209	mm
Distance Between Flanges:	9.95	in	253	mm
Recommended Maximum Wire Rope Diameter:	1/2	in	12.7	mm
Recommended Minimum Wire Rope Breaking Strength:	26600	lbf	12066	kgf
Approximate Shipping Weight:	82.0	lb	37.2	kg
Duty Cycle (intermittent per SAE J706 section 6.2):	565	ft	172	m
Mounting Bolt Torque:	35 - 40	ft*lbf	47 - 54	N*m
Maximum Layers of Wire Rope:	3 (with 1/2" dia. rope)			
Gear Reduction:	36:1			
Brake Type:	Disk			
Contactor / Remote Type:	N/A			

Drum Rotation

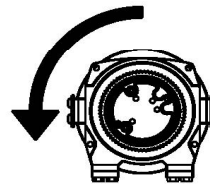

Viewed from Motor End

Standards Compliance

- 1. -SAE J706
- 2. -CE Machinery Directive 98/37/EC and 2006/42/EC

Performance By Layer- 1/2" (12.7 mm) dia. rope

Drum Layer	Line Load *			Line Speed 10 GPM		Line Speed 15 GPM		Drum Capacity	
	lbf	kgf	kN	ft/min	m/min	ft/min	m/min	ft	m
1	18000	8165	80.1	10.2	3.1	14.9	4.5	21	6.4
2	14727	6680	65.5	12.5	3.8	18.2	5.5	46	14.0
3	12461	5652	55.4	14.7	4.5	21.5	6.6	75	22.9

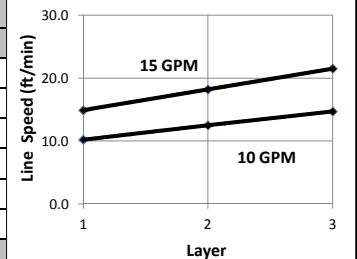

* Never exceed the Rated Pulling Force. Installation of a Rated Capacity Limiter is recommended.

First Layer Performance

Line Load		Pressure Drop at 10 GPM		Pressure Drop at 15 GPM		Duty Cycle
lbf	kgf	psi	BAR	psi	BAR	min/10min
0	0	113	7.8	162	11.2	N/A
3000	1361	345	23.8	400	27.6	N/A
6000	2722	599	41.3	663	45.7	N/A
9000	4082	867	59.8	930	64.1	N/A
12000	5443	1137	78.4	1196	82.5	N/A
15000	6804	1446	99.7	1546	106.6	N/A
18000	8165	1617	111.5	1816	125.2	N/A

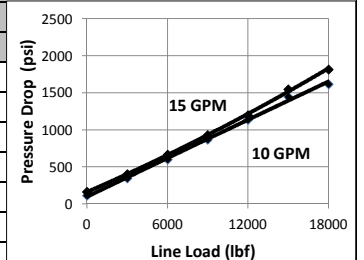

WARN INDUSTRIES, INC
Industrial Products

Customer Service (North America): 1.800.543.9276
Customer Service (International): 1.503.722.3008
FAX: 1.503.722.3000 www.warn.com

12900 S.E. Capps Road,
Clackamas, OR USA 97015



WARN Industrial Winch

Model	Part Number	Motor Type
Series 18-A-73 Hydraulic Winch Manual Clutch	74125	Hydraulic 7.3 ci (120 cc)

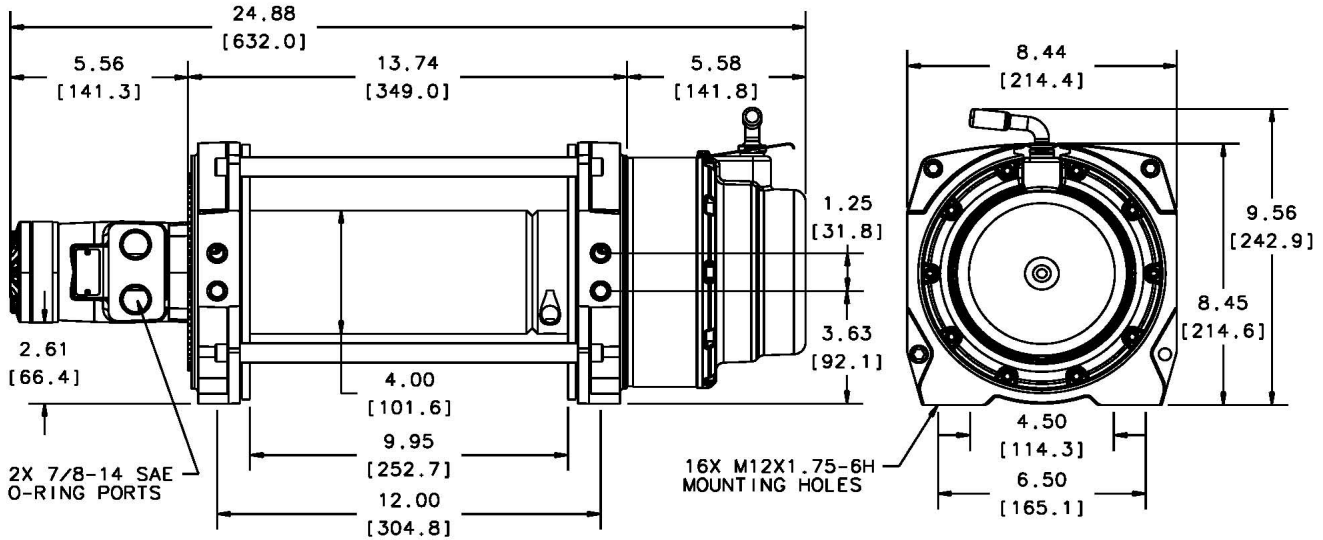

Motor / Contactor may be rotated in 90 degree increments. Clutch housing may be rotated in 72 degree increments.

Units are given in inches [millimeters], unless otherwise specified

Recommended Mounting- Always Observe Correct Drum Rotation			Hydraulic System Specifications	
Pull from bottom of winch	Pull from bottom of winch	Pull from top of winch	Maximum System Pressure:	2400 psi 166 BAR
			Maximum Motor Pressure Drop:	1816 psi 125 BAR
Feet down	Feet forward	Feet forward	Maximum Rated Input Flow:	15 GPM 57 LPM
Pull from top of winch	Pull from top of winch	Pull from top of winch	Control Valve Type:	3-position, 4-way, closed center, spring return (cylinder spool)
			Control Valve Schematic	
Feet down without angle brace	Feet down with angle brace	Angle Braces Only		
			Note: Drum rotates clockwise with Port A pressurized when viewed from gearbox end.	

WARN INDUSTRIES, INC
Industrial Products

Customer Service (North America): 1.800.543.9276
Customer Service (International): 1.503.722.3008
FAX: 1.503.722.3000 www.warn.com

12900 S.E. Capps Road,
Clackamas, OR USA 97015